



# INSTALLATION GUIDE

Protective skid plate  
TGB Blade 1000 LTX



**Full protection and ultra-light protection of your quad bottom, made of high quality HrdPE material, equipped with water and mud holes drainage. HrdPE cover characterizes good impact and deformation resistance.**

**Enjoy using it!**

# PROTECTIVE PLATE TGB BLADE 1000 LTX



The set of protective plates is made of a specially designed material. The protective plate, after taking even a large impact force, accumulates them and does not deform the material, returning to its original form. High quality and repeatability of production using the latest CNC technologies ensure ease and speed of assembly. Each plate is precisely adapted to a given quad model at the design stage, which guarantees the exact fit of the elements to the structure. The kit includes all the necessary elements, there is no need for additional modifications or drilling. Read the instructions before starting the assembly. The assembly instructions are for the TGB Blade 1000 LTX model only and cannot be used with other quad models. The surface of the material is easy to clean. Another advantage is easy access to changing fluids without the need to disassemble the plates. It is very light compared to other record makers.

## INSTALLATION KIT

It contains a set of protective plates with mounting elements (screws, mounting plates, washers, sleeves, nuts and additional fastening elements) each of the plates has its own individual installation kit, packed in separate bags for each of the plates. It is recommended to unpack the installation elements only for the currently installed plates, which will avoid mistakes and mixing of the fixing elements. Re-sorting can be done according to with a list of mounting items attached.

## TOOLS REQUIRED FOR ASSEMBLY

Allen key No. 4 (for M6 screws) and 5 (for M8)

## DIRECTIONS

Screw the bolts fastening the plates to the structure elements, which will enable their position to be adjusted, and then tighten them sensitively, without breaking the thread. After driving a dozen or so kilometers, check whether the mounting screws have been properly tightened, any loose ones must be tightened, also with feeling :-)



The figure shows the orientation of the taps, bottom view. To properly connect the protection plates to the frame structure, the catches should settle from the top of the structural tubes, this applies to all connections of this type specified in the diagram. The hooks and pipes are marked in red along with their orientation. Sufficient space for hands and tools allows the mounting of catches of the control arm covers at the marked points, without disassembling any other components.

## INSTALLATION



**CAUTION**

The easiest way to mount it is in a tilted position on the rear part of the quad bike.

### ATTENTION: CAREFULLY SECURE ALL FASTENERS TO ENSURE SAFETY

The manual provides a view of the placement of elements helping to localize fasteners and the use of individual connecting elements.

Start the assembly sequence with the front plate [1] and the fastening plate A1.

## INSTALLATION OF PROTECTIVE PLATES (1, 2, 3, 4, 5, 6, 7)

**[Plate no. 1]** When assembling the protective plate, do not unscrew the front metal plate that comes with your ATV. Start from tightening the M6 screws (**points marked with red circles on the diagram**) then perform the fastening with M8 screws, which screw is marked in yellow on the diagram as screw no. 1 with square elements A (Fig. 3). Scheme 1+A. The last step is screwing the connecting plate A1. **The mounting plate is installed between the screwed-on plastic cover and the quad's chassis.**

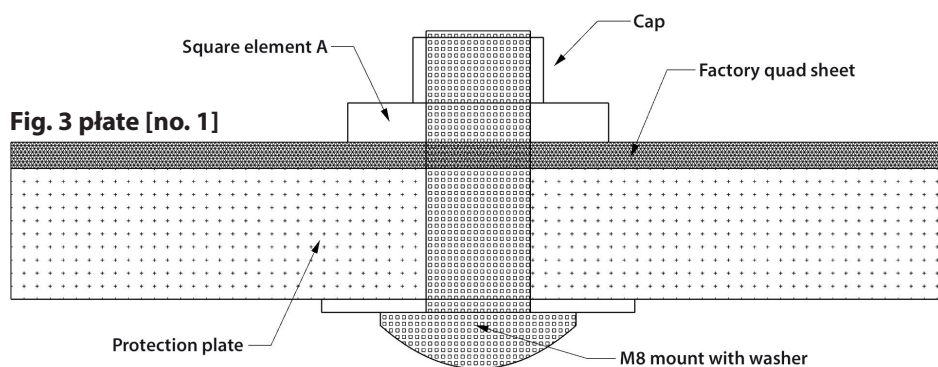

### INFORMATION

Fastened with M8 screws with square elements A we carry out through the notches located in the factory plate of the quad cover

**[Plate no. 2]** Place the washers on the screws. Screw in from above through the outer feet of the leg space. Install two hooks and screw 2-3 threads into the center protection plate, the hooks will hold the plate on the quad frame. Install the plate on the screws located in the leg space. Put washers on the bolts, then the nuts B twisting with your fingers. Attach the tabs through the square holes to the frame tubes, tighten, so that the tabs do not fall out. Then adjust the position of the plate, place the mounting plate A2 and tighten it. **NOTE** Place the distance sleeves C on the bolt behind the protective plate (**points marked with red circles in the diagram**).

**[Plate no. 3]** Place the back protection plate over the appropriate holes and install the screws with washers. Before tightening the bolts, set the rear protection plate to the correct position and then fully tighten all 9 bolts.

**[Plate no. 4 and 5]** First, put the cover and install the hooks (orientation on the diagram) to the **front rocker arms** covers, do not fully tighten the screws, center the cover on the appropriate holes and tighten the screws, not forgetting the washers :-). Position the cover and tighten the screws. Make a double check, if there is no contact between the wheel and the guard by turning your steering wheel completely right and left, in the event of a contact, make the proper adjustment of the guard by moving it to the correct position. Also check, if there is sufficient space between the **front protection plate** and the rocker arm covers to avoid contact in the event of complete compression of the suspension.

**[Plate no. 6 and 7]** First, put the cover and install the hooks (orientation on the diagram) to the **rear rocker arms** covers, do not fully tighten the screws, center the cover on the appropriate holes and tighten the screws, not forgetting the washers :-). Position the cover and tighten the screws. Make a check that there is no contact between the wheel and the guard by turning your steering wheel completely right and left, in the event of a contact, make the proper adjustment of the guard by moving it to the correct position. Also check that there is adequate space between the rear protective plate and the rocker arm covers to avoid contact in the event of complete compression of the suspension.

### INFORMATION

Sufficient space for the hands allows mounting clamps of the control arm covers at the marked points after attaching the cover to them. To do this, tighten the cover with the screws on the front and rear transverse arms (points marked with circles in the diagram). Clamp the clamp (without the screw on the other side) on the swing arm tube (observe the orientation of the clamps in the diagram), move the thread to the hole in the protective cover and fix the clamp with the screw (**Fig. 1 and 2**).

# Diagram of the arrangement of mounting elements - TGB BLADE 1000 LTX

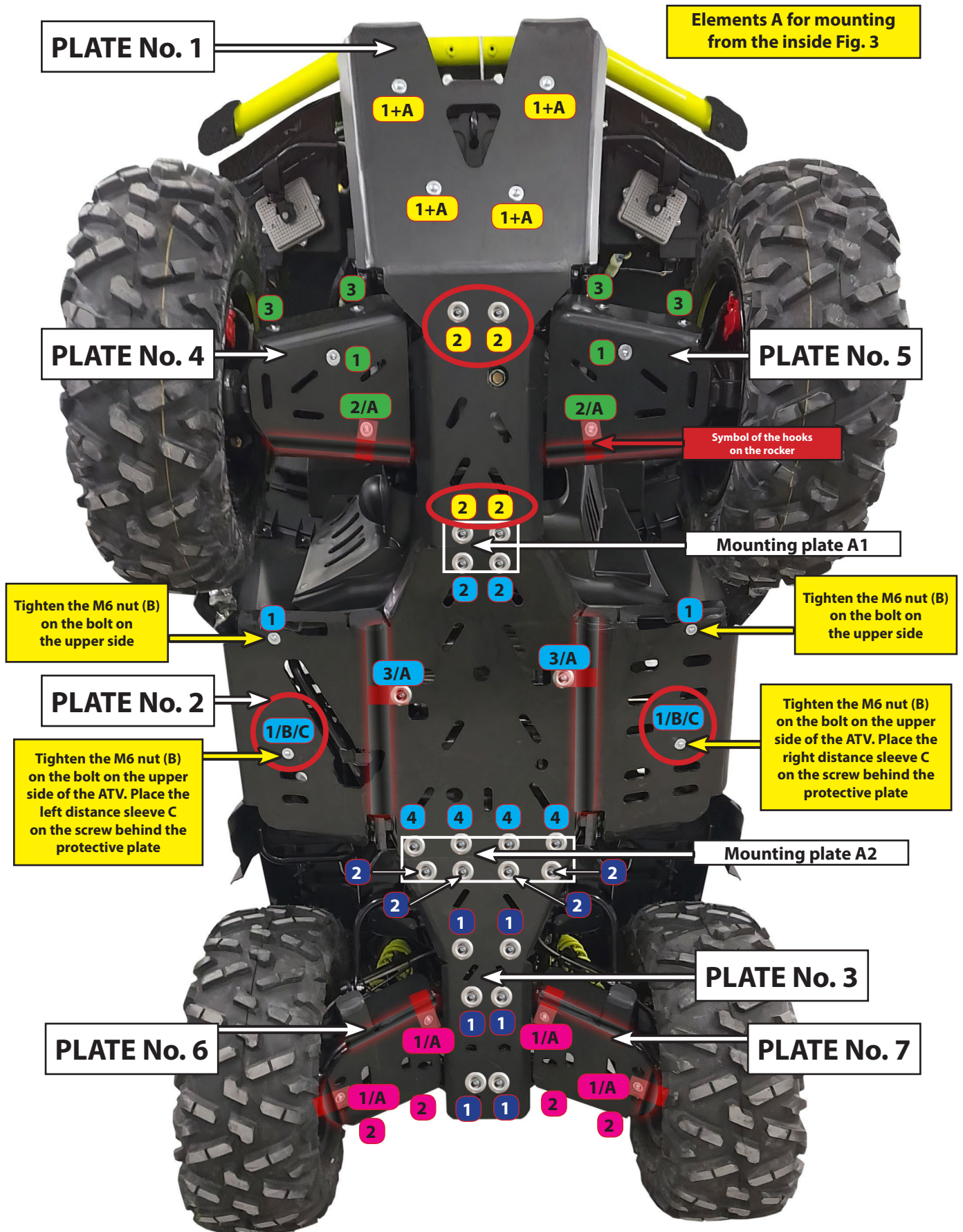

Arrangement of mounting plates connecting the protective plates - TGB BLADE 1000 LTX

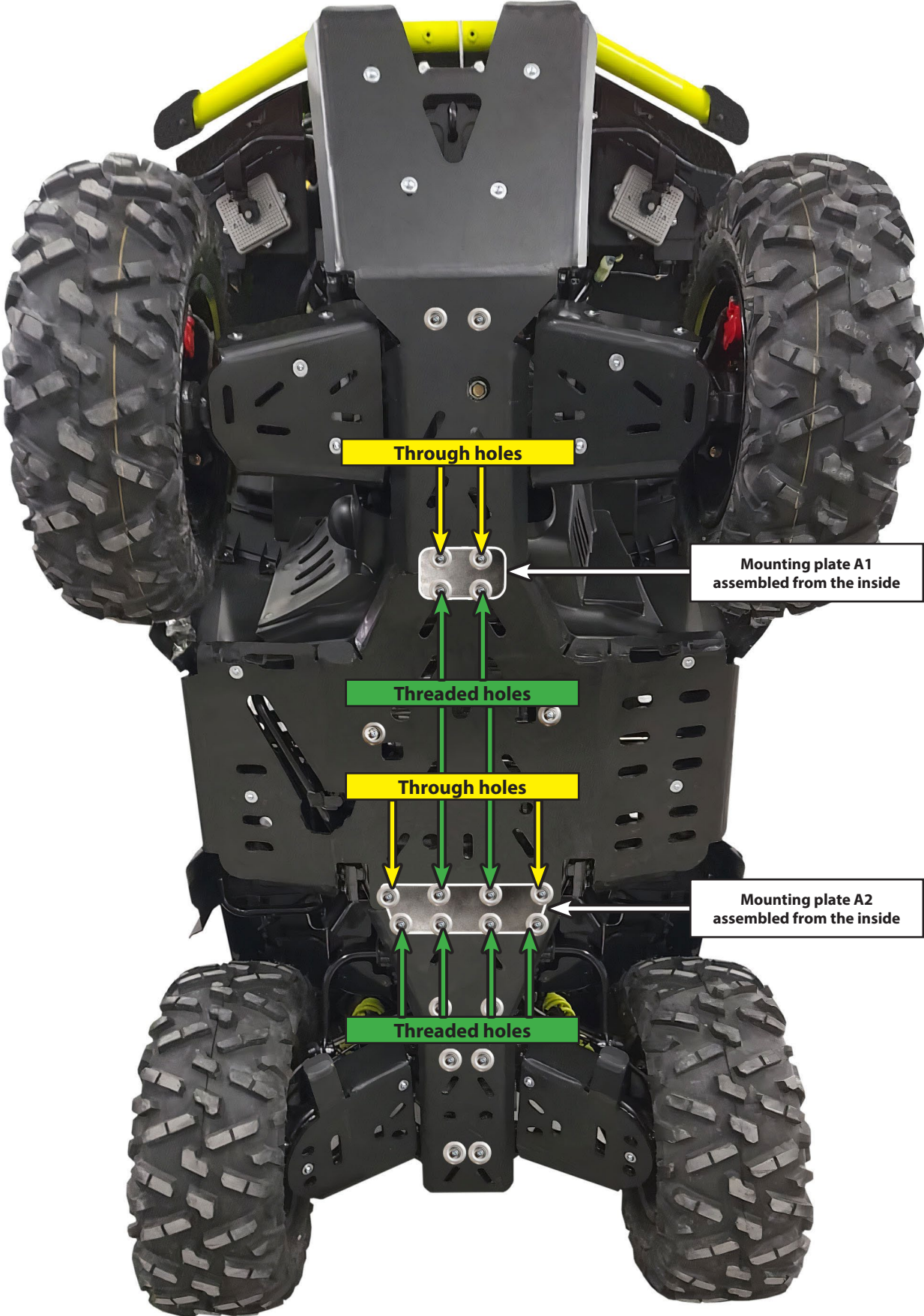

Through holes

Mounting plate A1 assembled from the inside

Threaded holes

Through holes

Mounting plate A2 assembled from the inside

Threaded holes

# List of mounting elements - TGB BLADE 1000 LTX

## PLATE No. 1

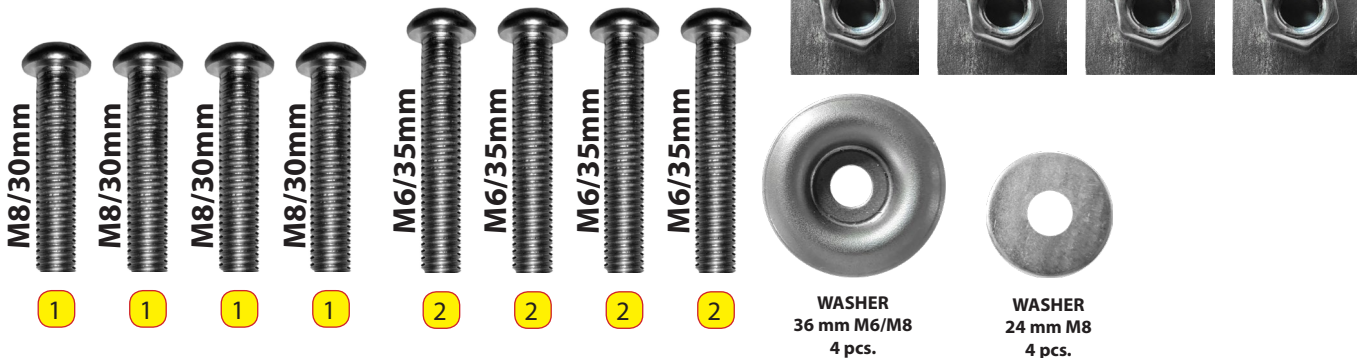

## PLATE No. 2

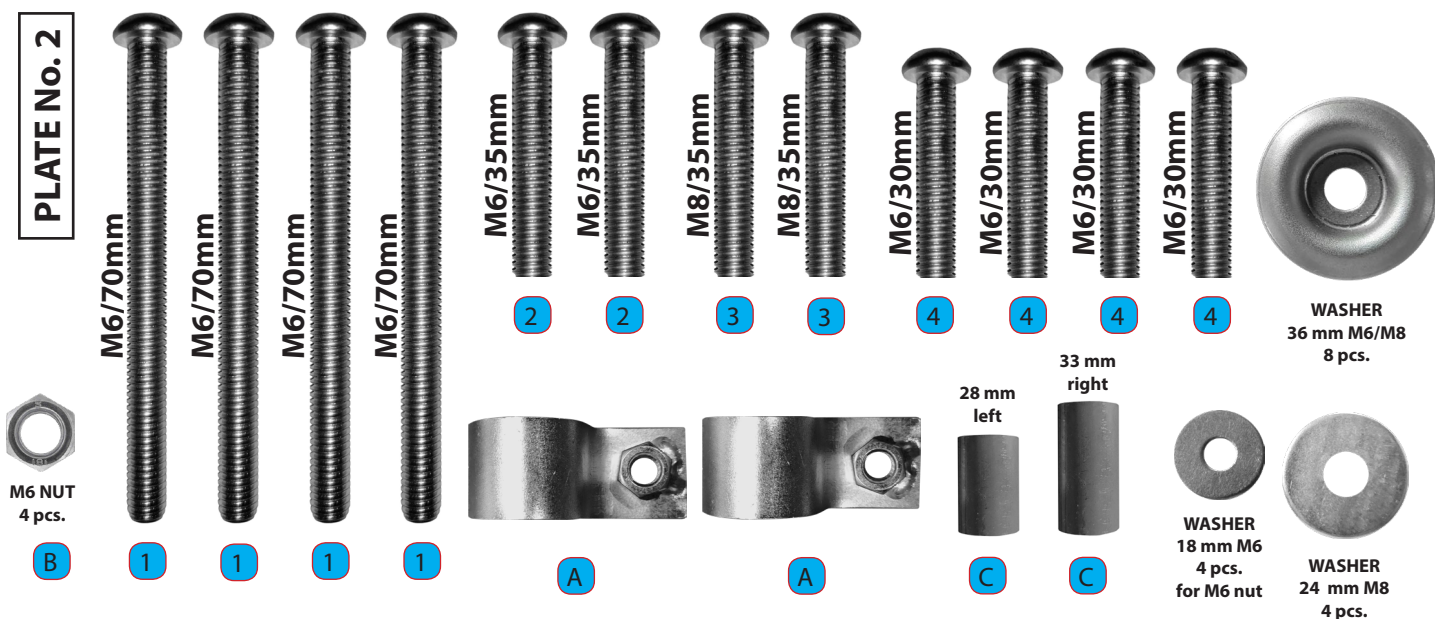

## PLATE No. 3



## PLATE No. 4

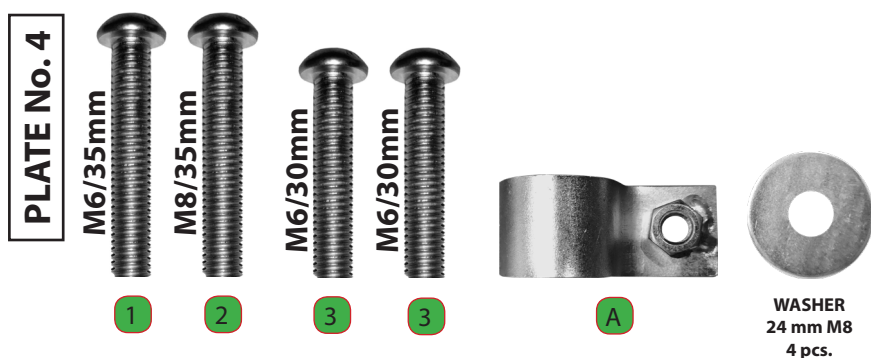

**PLATE No. 5**

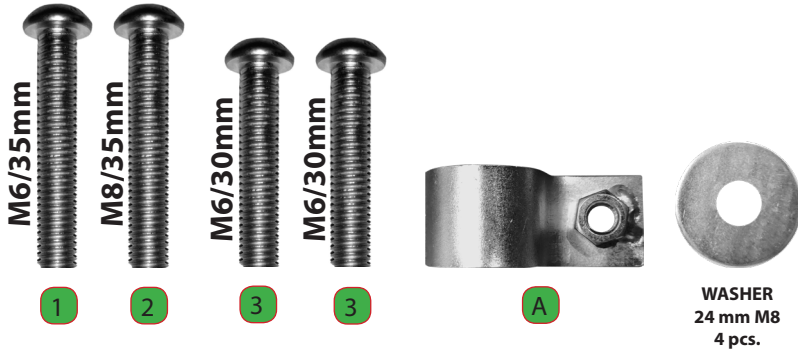

**PLATE No. 6**



**PLATE No. 7**

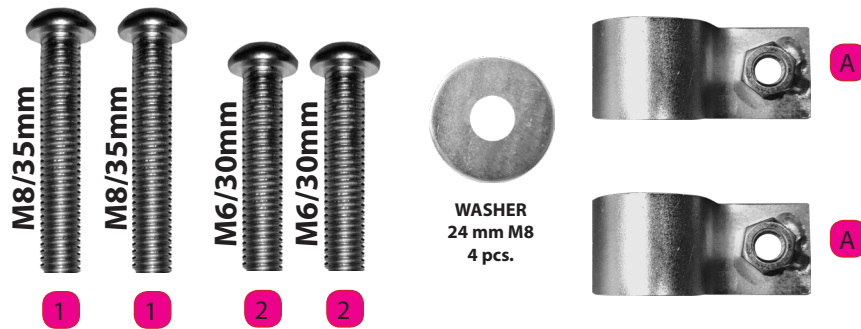

**MOUNTING PLATES TGB BLADE 1000 LTX**

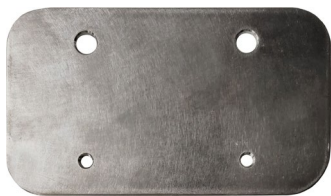

**MOUNTING PLATE A1**



**MOUNTING PLATE A2**

**PROTECTIVE PLATES USE**

You have just set up your hood, uh, it wasn't that bad. During the crossings - when using, watch out for protruding stones, trunks or roots. Remove the mud after the expedition easily with a pressure washer, a water hose, for this activity you do not have to turn your ATV upside down, because the mud does not stick to the protective plates made of **HrdPE** material. Although our **HrdPE** covers themselves float on the water, remember that when the water level is too high, they will not carry your quad on it. We recommend to watch the films :-)